

TOP VIEW

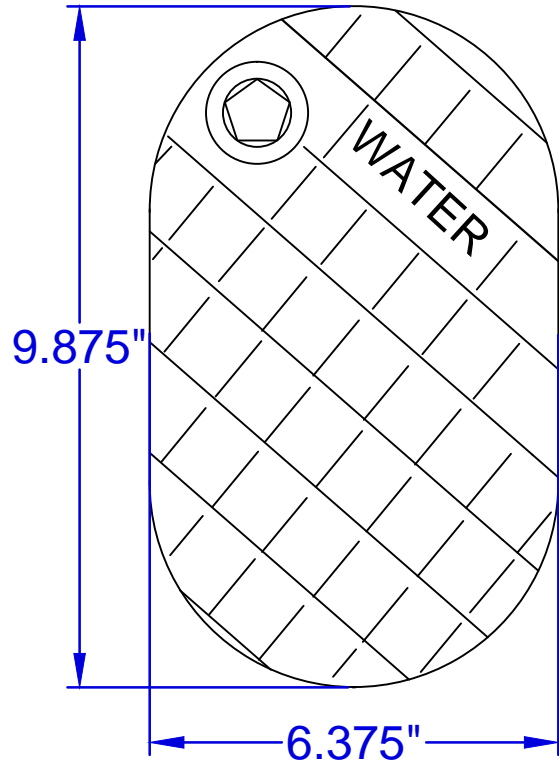

BOTTOM VIEW

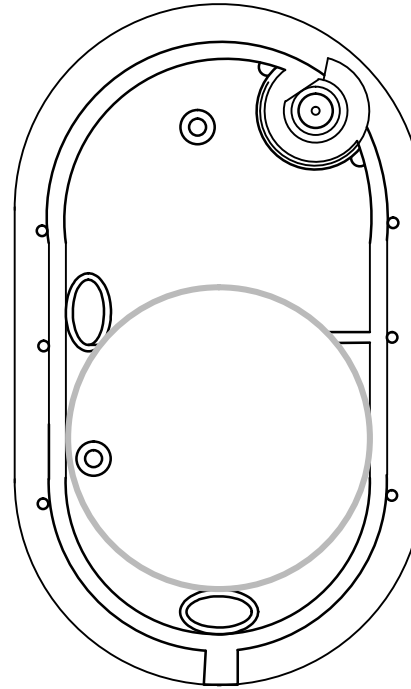

SIDE VIEW

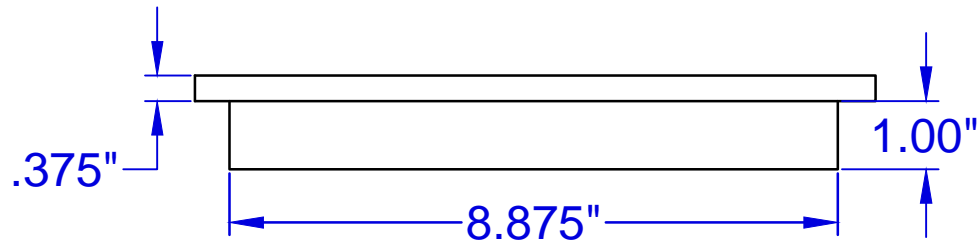

PROPRIETARY

General Notes

2	DLM	3/23/18
1	DLM	1/12/15
Revision	Drawn By	Date

WOMAN OWNED
&
MADE IN THE USA

MATERIAL: MAIN LID POLYMER
FINISH PROCESS
SURFACE FINISH 125

FINISH OR TREATMENT

(UNLESS OTHERWISE SPECIFIED)
BEFORE FINISH PROCESS:
DIMENSIONS IN INCHES
(DIMENSIONS) IN MILLIMETERS
TOLERANCES UNLESS SPECIFIED: XXX+.0010 (.0254)
XXX+.005 (.127)
XX+.010 (.254)
ANGLES +.010 1/2"
REMOVE BURRS AND BREAK CORNERS
.005 (.127) MAX. UNLESS SPECIFIED
INSIDE CORNERS .010 R. MAX.
CONCENTRICITY .005 F.I.M.

NICOR, INC.

PROPRIETARY NOTICE
This document, whether patentable or non-patentable subject matter, embodies proprietary and confidential information and is the exclusive property of NICOR, INC. It may not be reproduced, used or disclosed to others for any purpose except that for which it is loaned, and it shall be returned on demand. All rights reserved.

JEFF COOK
NICOR
100 COMMONS RD#7-355
DRIPPING SPRINGS, TX
78620

Meat Lid Home
6X9 Oval Worm Gear
FLAT

Drawing Number CUSTOMER DRAWING	Sheet 01
LID NUMBER 6X9PWATH	