

TOP VIEW

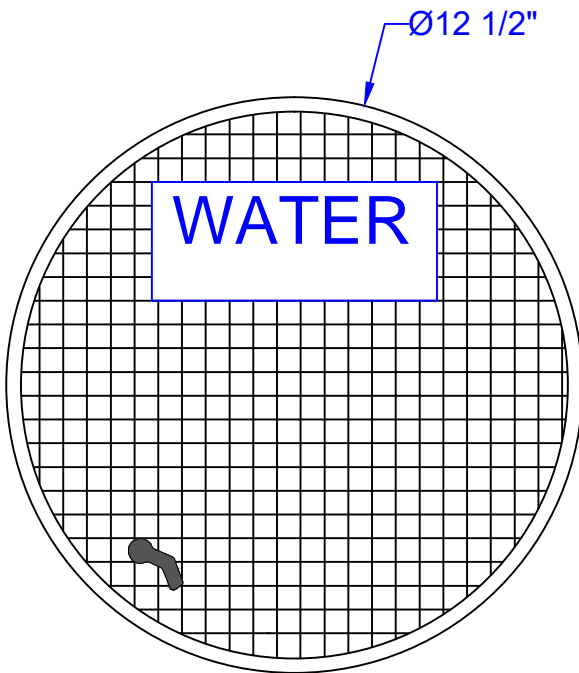

SIDE VIEW

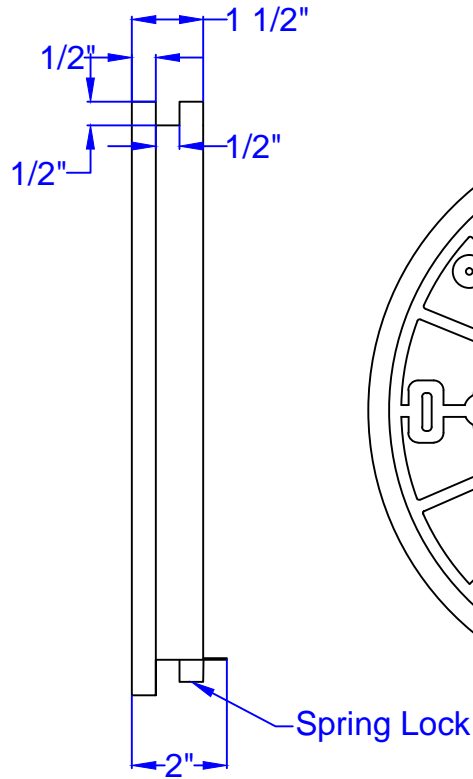

BOTTOM VIEW

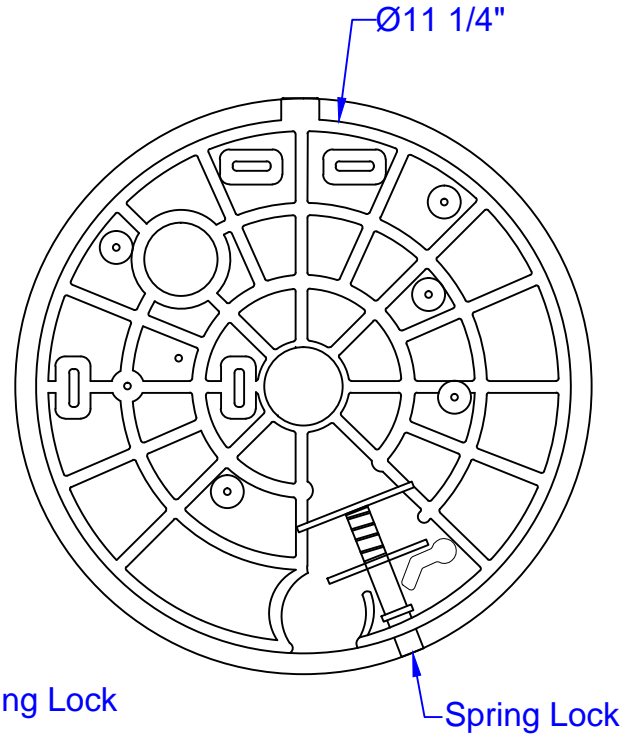

PROPRIETARY

General Notes

3	DLM	7/11/17
2	LRM	10/6/15
1	LRM	11/04/14
Revision	Drawn By	Date

MATERIAL: MAIN LID POLYMER
 FINISH PROCESS
 SURFACE FINISH 125

FINISH OR TREATMENT
 (UNLESS OTHERWISE SPECIFIED)
 BEFORE FINISH PROCESS:
 DIMENSIONS IN INCHES
 (DIMENSIONS IN MILLIMETERS
 TOLERANCES UNLESS SPECIFIED: XXX+.0010 (.0254)
 XXX+.005 (.127)
 XX+.010 (.254)
 ANGLES +.010 1/2"
 REMOVE BURRS AND BREAK CORNERS
 .005 (.127) MAX. UNLESS SPECIFIED
 INSIDE CORNERS .010 R. MAX.
 CONCENTRICITY .005 F.I.M.

NICOR, INC.
PROPRIETARY NOTICE
 This document, whether patentable or non-patentable subject matter, embodies proprietary and confidential information and is the exclusive property of NICOR, INC. It may not be reproduced, used or disclosed to others for any purpose except that for which it is loaned, and it shall be returned on demand. All rights reserved.

JEFF COOK
 NICOR
 100 COMMONS RD#7-355
 DRIPPING SPRINGS, TX
 78620

Project Name
 12.5 Type C Lid

Drawing Number 12.5 Type C	Sheet 01
Date 7/11/17	