

TOP VIEW

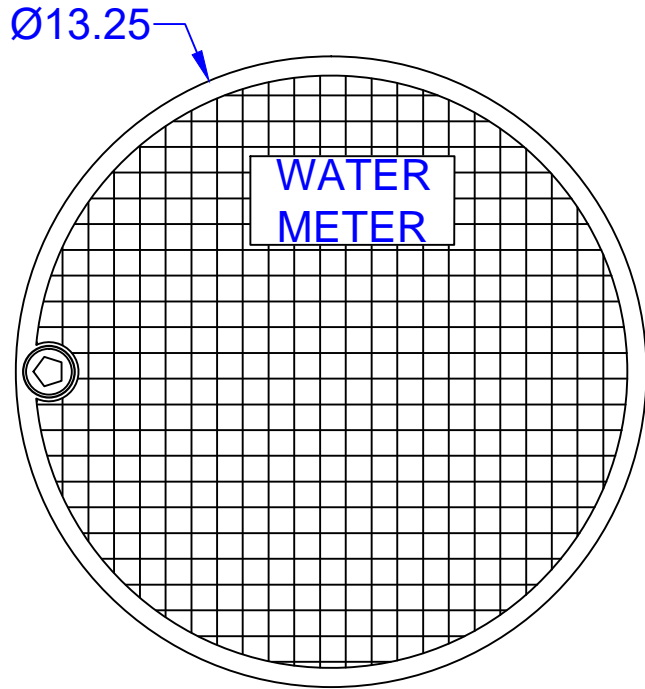

BOTTOM VIEW

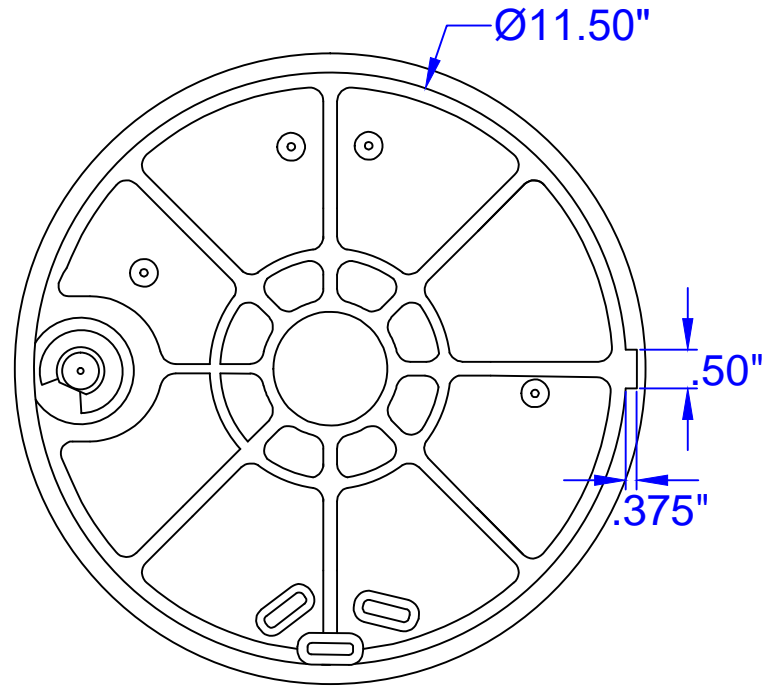

SIDE VIEW

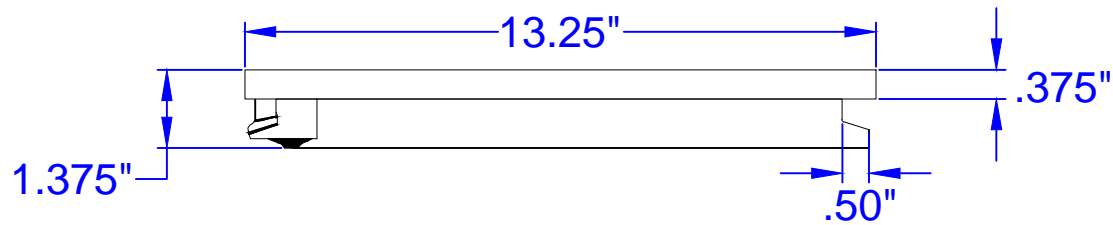

**PROPRIETARY**

General Notes

Notes: H2O Load Rating

2	DLM	2/20/18
1	DLM	5/24/16
Revision	Drawn By	Date

MATERIAL: MAIN LID POLYMER  
FINISH PROCESS  
SURFACE FINISH 125

FINISH OR TREATMENT  
(UNLESS OTHERWISE SPECIFIED)  
(UNLESS OTHERWISE SPECIFIED)  
BEFORE FINISH PROCESS:  
DIMENSIONS IN INCHES  
(DIMENSIONS) IN MILLIMETERS  
TOLERANCES UNLESS SPECIFIED: XXX+.0010 (.0254)  
XXX+.005 (.127)  
XX+.010 (.254)  
ANGLES +.010 1/2"  
REMOVE BURRS AND BREAK CORNERS  
.005 (.127) MAX. UNLESS SPECIFIED  
INSIDE CORNERS .010 R. MAX.  
CONCENTRICITY .005 F.I.M.

**NICOR, INC.**  
PROPRIETARY NOTICE  
This document, whether patentable or non-patentable subject matter, embodies proprietary and confidential information and is the exclusive property of NICOR, INC. It may not be reproduced, used or disclosed to others for any purpose except that for which it is loaned, and it shall be returned on demand. All rights reserved.

JEFF COOK  
NICOR  
100 COMMONS RD#7-355  
DRIPPING SPRINGS, TX  
78620

Project Name  
13.25 Comco  
with Worm Gear

Drawing Number CUSTOMER DRAWING	Sheet 01
Date 13" COMCO	