

GT SPLICE INSTALLATION INSTRUCTIONS 22-24 AWG

STEP 1 Attach splice block to mounting surface using (2) Phillips #8 x 5/8" screws. Or just lie on flat surface if not mounting.

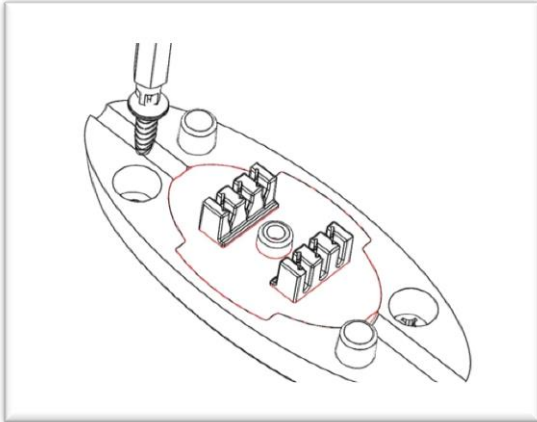

STEP 2 Using a finger hold down all three wires and seat them using punch-down tool P/N 195-00404.

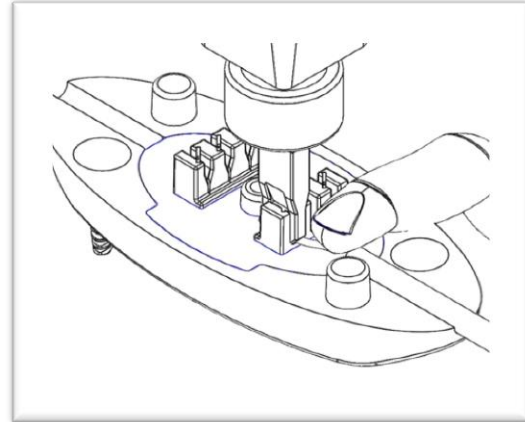

STEP 3 Being sure to line up wire colors use Punch-down tool to seat the remaining wires.

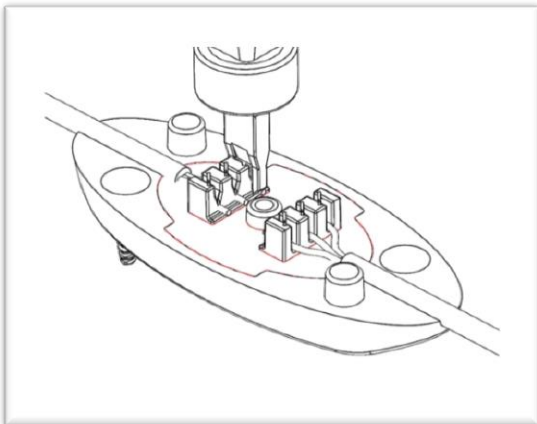

STEP 4 Secure the top using (1) #8 x 5/8" screw.*

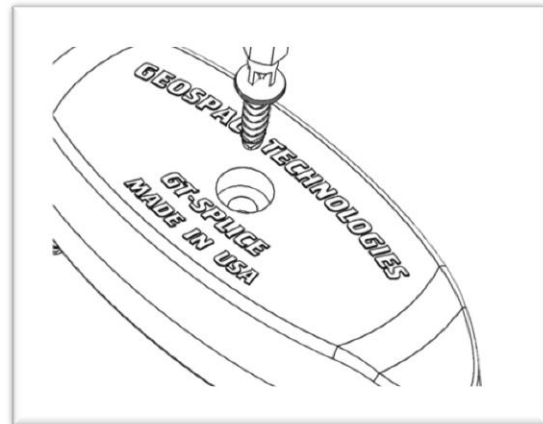

*NOTE: The top is rotated 180 degrees for shipping purposes and the halves will not come together in the shipping position.