

TOP VIEW

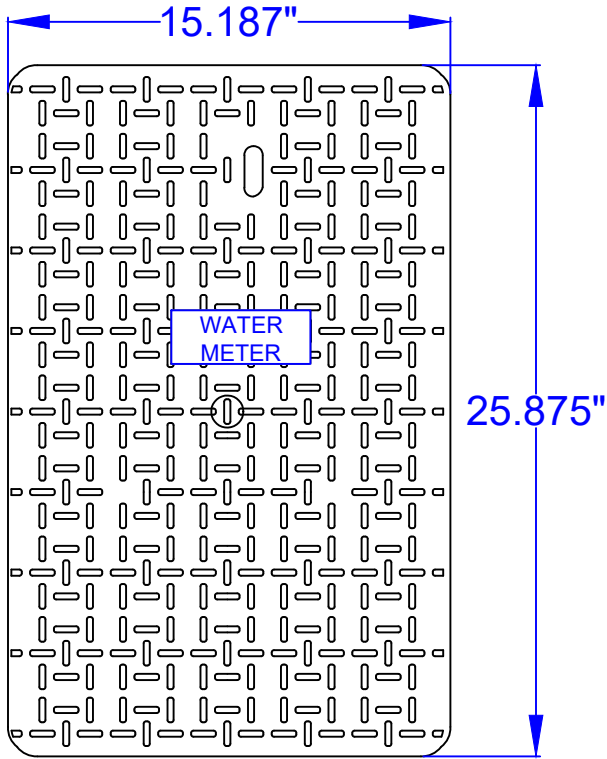

BOTTOM VIEW

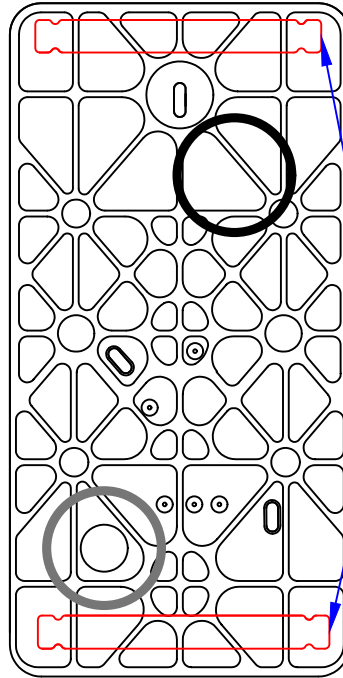

SIDE VIEW

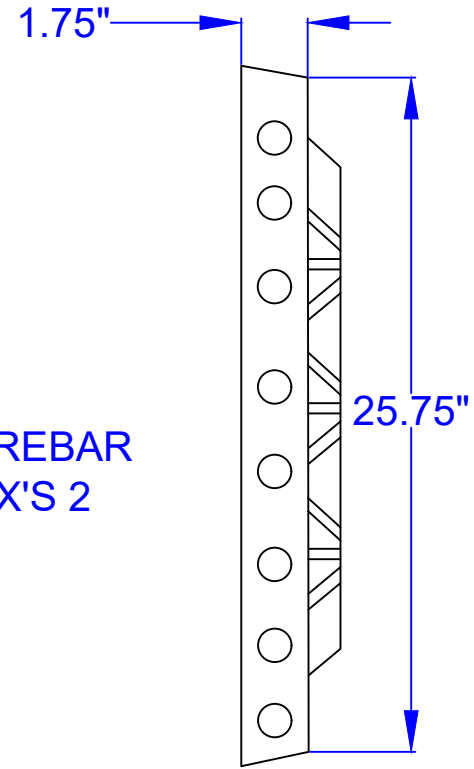

SIDE WIDTH VIEW

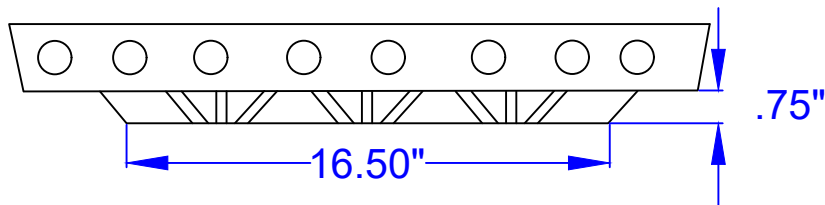

PROPRIETARY

General Notes

Lid Weight: 18.8 lbs

Revision	Drawn By	Date
5	DLM	11/14/19
4	DLM	3/6/19
3	DLM	3/21/18
2	DLM	3/9/18
1	DLM	12/4/17

MATERIAL: MAIN LID POLYMER
FINISH PROCESS
SURFACE FINISH 125

FINISH OR TREATMENT
(UNLESS OTHERWISE SPECIFIED)
BEFORE FINISH PROCESS:
DIMENSIONS IN INCHES
(DIMENSIONS IN MILLIMETERS
TOLERANCES UNLESS SPECIFIED: XXXX+.0010 (.0254)
XXX+.005 (.127)
XX+.010 (.254)
ANGLES ±.010 1/2"
REMOVE BURRS AND BREAK CORNERS
.005 (.127) MAX. UNLESS SPECIFIED
INSIDE CORNERS .010 R. MAX.
CONCENTRICITY .005 F.I.M.

NICOR, INC.

PROPRIETARY NOTICE
This document, whether patentable or non-patentable subject matter, embodies proprietary and confidential information and is the exclusive property of NICOR, INC. It may not be reproduced, used or disclosed to others for any purpose except that for which it is loaned, and it shall be returned on demand. All rights reserved.



MAG #3

Drawing Number
CUSTOMER DRAWING

Sheet
01

Date
15.187x25.875